

Distributed Traffic Control Systems

Addressing the safety and availability challenges

What is meant by a distributed traffic control system

— Plus+ Resilience by Design

Traditional traffic control systems use many cables to connect street furniture to the traffic controller

Cabling has many cores

- Large numbers of individual connections
- Significant cable identifying and testing required during commissioning

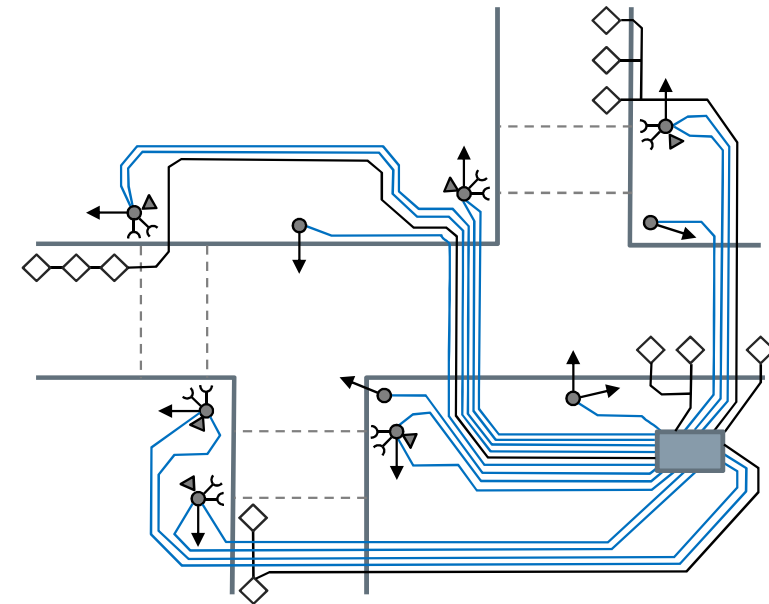

Typical traditional cabling

What is meant by a distributed traffic control system

— Plus+ Resilience by Design —

Traditional traffic control systems use many cables to connect street furniture to the traffic controller

Cabling has many cores

- Large numbers of individual connections
- Significant cable identifying and testing required during commissioning



What is meant by a distributed traffic control system

— Plus+ Resilience by Design

A distributed system uses intelligence spread throughout the intersection to significantly reduce individual cable connections

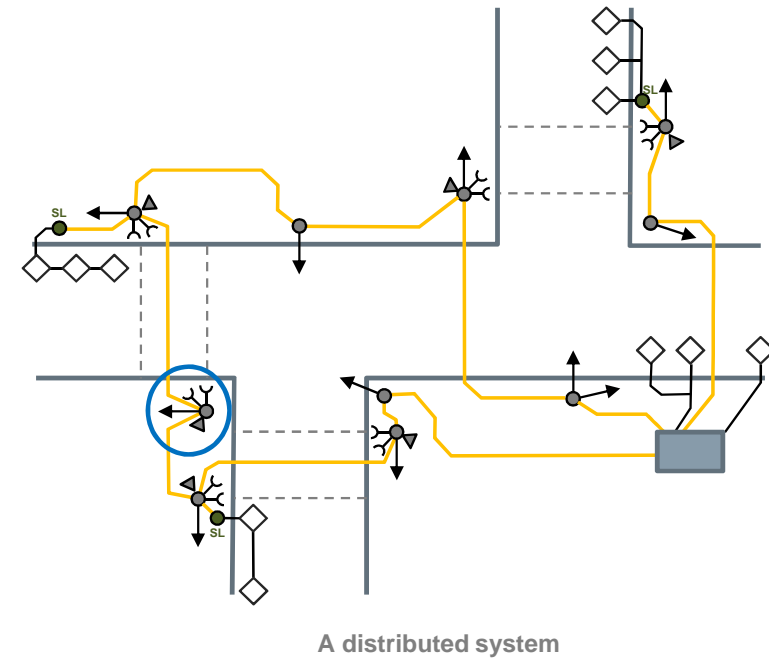
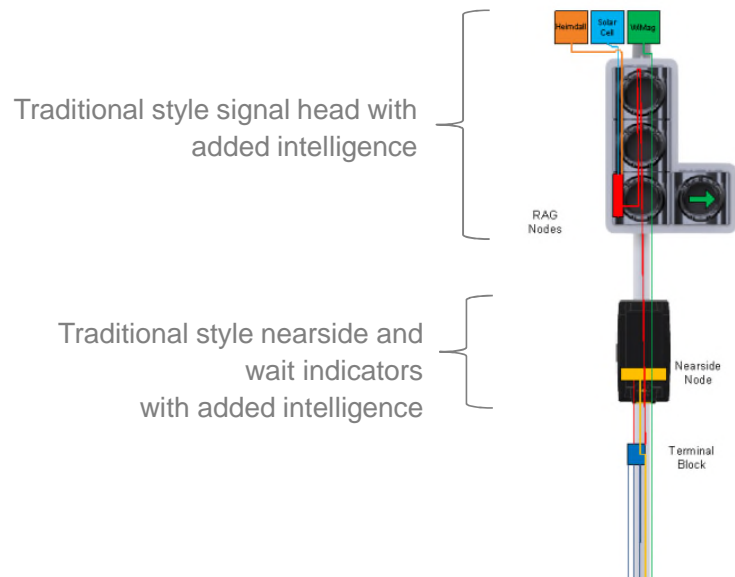

What is meant by a distributed traffic control system

— Plus+ Resilience by Design

A distributed system uses intelligence spread throughout the intersection to significantly reduce individual cable connections

Conceptually cabling could be arranged as:

- Arms
- Rings

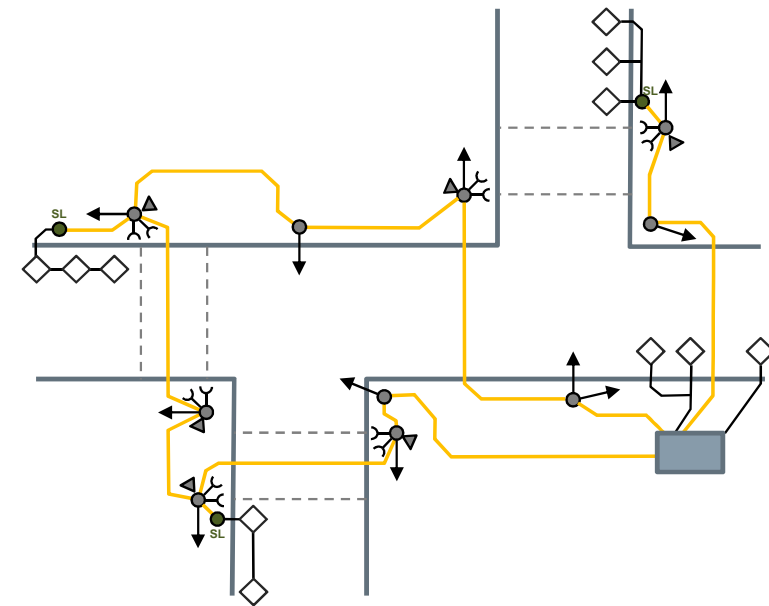

A distributed system

What is meant by a distributed traffic control system

— Plus+ Resilience by Design

A distributed system uses intelligence spread throughout the intersection to significantly reduce individual cable connections

Conceptually cabling could be arranged as:

- Arms
- Rings
- Stars

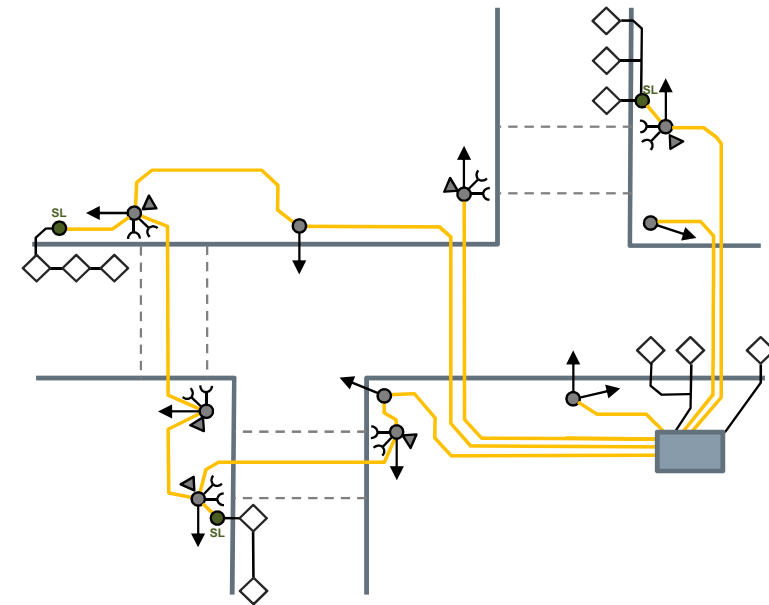

A distributed system

What is meant by a distributed traffic control system

— Plus+ Resilience by Design

A distributed system uses intelligence spread throughout the intersection to significantly reduce individual cable connections

Ideally cabling should continue to use standard cable types

➤ **i.e. 4 core loop feeder**

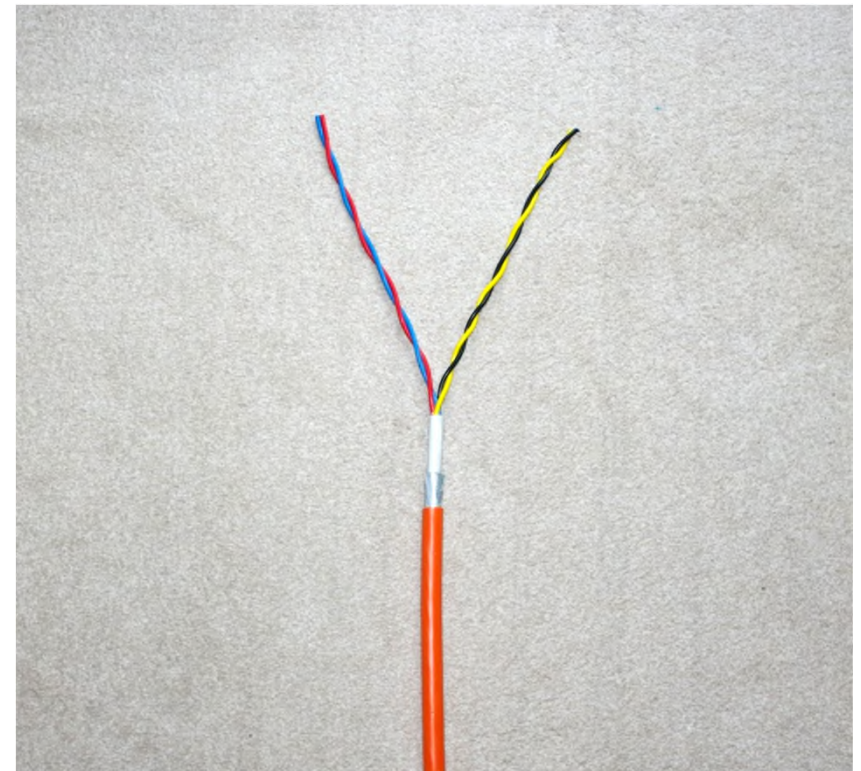

What is meant by a distributed traffic control system

— Plus+ Resilience by Design

A distributed system uses intelligence spread throughout the intersection to significantly reduce individual cable connections

Ideally cabling should continue to use standard cable types

➤ **i.e. 4 core loop feeder**

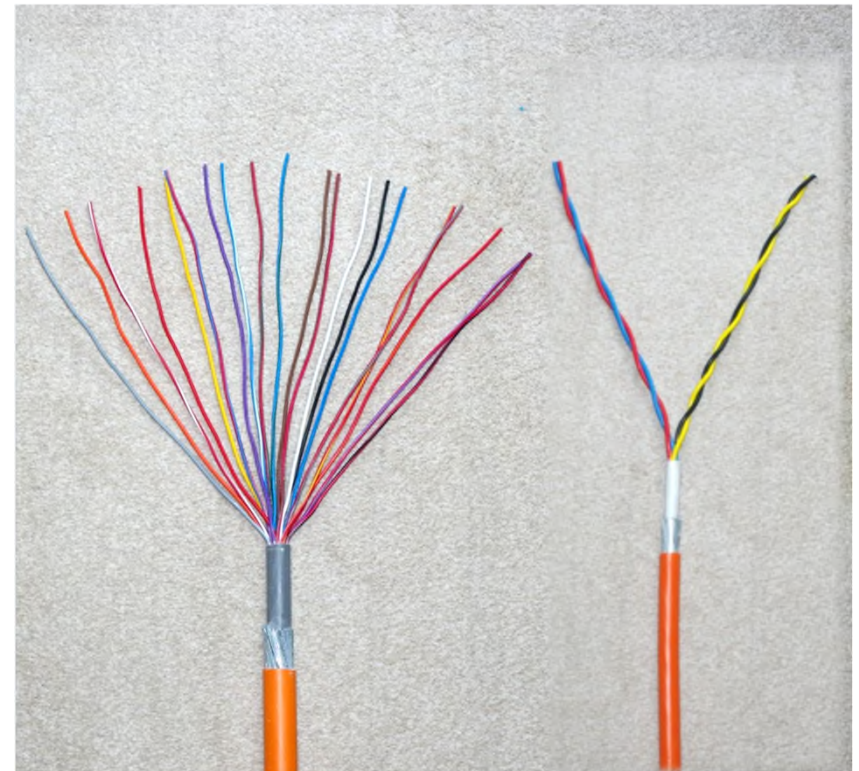

Potential benefits of a distributed traffic control system

— Plus+ Resilience by Design

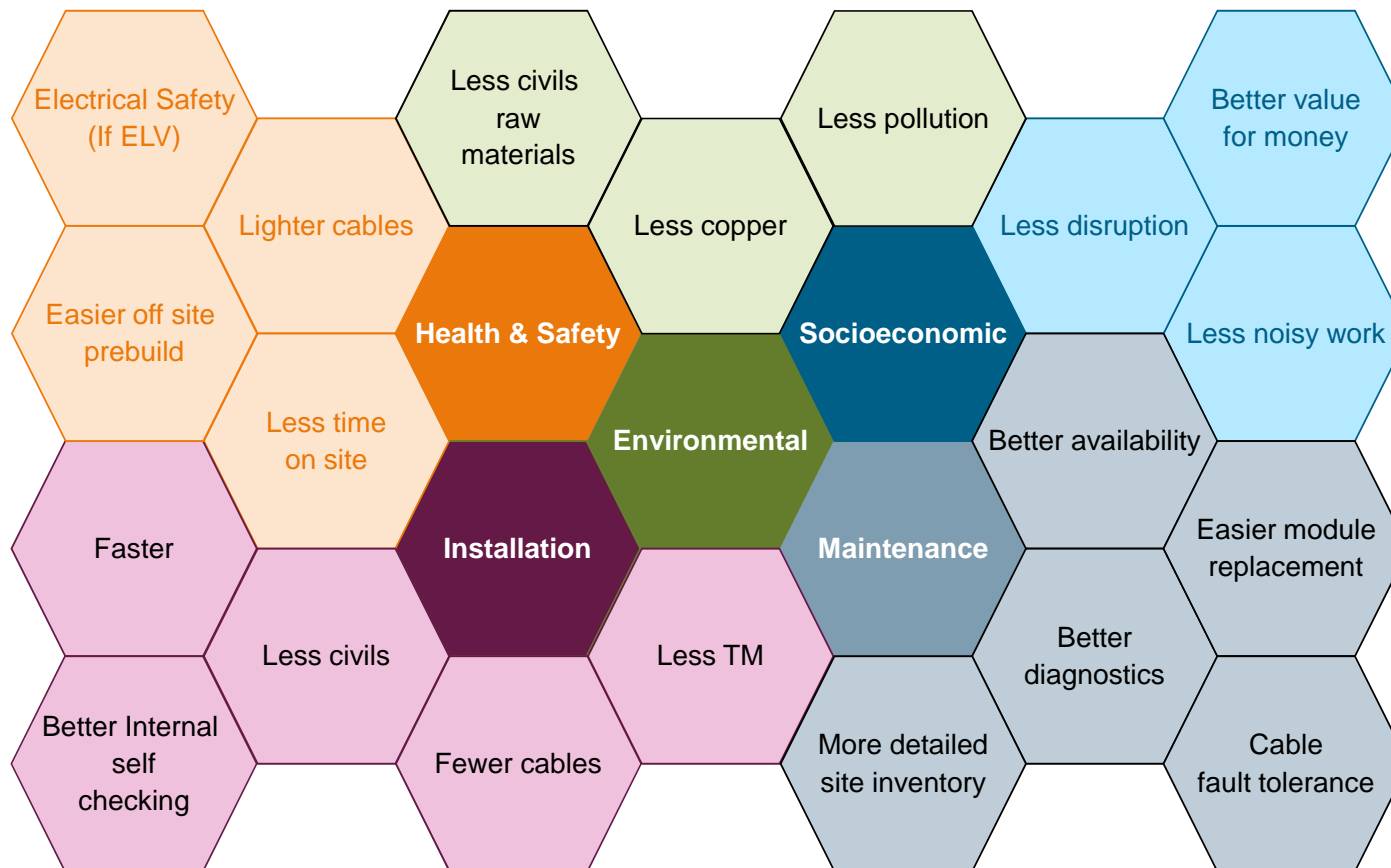

Some key safety and availability challenges

— Plus+ Resilience by Design —

Ensuring conflict and correspondence performance

Avoiding partial dimming due to cable volt drops

Maintaining electrical safety

Ensuring distributed intelligence does not reduce intersection availability



Some key safety and availability challenges

– Plus+ Resilience by Design

Ensuring conflict and correspondence performance

Avoiding partial dimming due to cable volt drops

Maintaining electrical safety

Ensuring distributed intelligence does not reduce intersection availability

Many other challenges also need to be addressed to ensure a successful solution, for example

- ❖ How to easily configure the system to allocate phases etc to nodes around the intersection
- ❖ How to ensure topography design for a site will actually work – taking into account data and power budgets
- ❖ How to prevent signal displays (red, amber, green) from being incorrectly connected on street
- ❖ How to eliminate the need for traditional detector loop feeder connections back to the controller

Some key safety and availability challenges

— Plus+ Resilience by Design

Ensuring conflict and correspondence performance

Avoiding partial dimming due to cable volt drops

Maintaining electrical safety

Ensuring distributed intelligence does not reduce intersection availability



- ❖ Make each signal node fail safe in its own right, so it cannot illuminate a signal incorrectly, even under fault conditions
 - Two processor safety and validation, with independent means to extinguish node signals in the event of a fault
- ❖ Use proprietary secure and authenticated communications
- ❖ Use secret 'monitor validation' processes to continually test system response to potential errors
- ❖ Use robust and simple (for the installer) processes to ensure individual signal nodes are correctly allocated to phases

Some key safety and availability challenges

— Plus+ Resilience by Design

Ensuring conflict and correspondence performance

Avoiding partial dimming due to cable volt drops

Maintaining electrical safety

Ensuring distributed intelligence does not reduce intersection availability



- ❖ Eliminate the dependence on signal voltage to determine when signals should dim
(Critical if multiple signals are to be successfully powered from single cable)
 - Design signal nodes to illuminate signals at the correct level across a wide range of supply voltage at the node
 - Set required dimming level centrally as part of the secure communications messaging to the nodes
- ❖ Does offer opportunities for selectable dimming levels (site to site) as once was the case with incandescent signals

Some key safety and availability challenges

— Plus+ Resilience by Design

Ensuring conflict and correspondence performance

Avoiding partial dimming due to cable volt drops

Maintaining electrical safety

Ensuring distributed intelligence does not reduce intersection availability



- ❖ Deliver a fully ELV system only
 - Reinforces the need to ensure that signal dimming is not voltage dependent
- ❖ Continue to ensure that provision is made to allow all on-street infrastructure (poles, pedestrian units etc) to be properly earthed
- ❖ Continue to ensure that individual passively safe poles can be electrically isolated in the event they are struck
 - But for maximum availability ensure that the overall system is able to be maintained in operation

Some key safety and availability challenges

— Plus+ Resilience by Design

Ensuring conflict and correspondence performance

Avoiding partial dimming due to cable volt drops

Maintaining electrical safety

Ensuring distributed intelligence does not reduce intersection availability



- ❖ Make each signal node fail safe in its own right, so it cannot illuminate a signal incorrectly, even under fault conditions
 - Allows failure of the node to be tolerated and the rest of the intersection to continue to function
- ❖ Provide potential for a cabling architecture that is tolerant of faults (i.e. A ring topography)
- ❖ Provide a fault tolerant power supply system with redundancy
- ❖ Enable replacement of key system components (nodes, power supplies etc) whilst the intersection remains operational
 - Make components 'hot swappable' where possible

By appropriately designing the architecture, components and tools used in Distributed Traffic Control systems, the complex challenges of such systems can be met, ensuring delivered intersection are as efficient as possible to install and offer the highest level of availability throughout their design life

A photograph of a dark asphalt road stretching into the distance. In the foreground, a large white question mark is painted on the road surface. The road leads to a fork in the road, with two paths branching out. The background shows a vast, flat landscape under a dark, overcast sky. In the top right corner, there is a white rectangular box containing the Siemens logo and tagline.

SIEMENS
Ingenuity for life

Questions

Questions

Distributed Traffic Control Systems

Addressing the safety and availability challenges